

IMPORTANT INFORMATION

For any installation problem please contact our Customer Service at the number +39-0172.812411 operating Monday to Friday from 8:30 to 12:30 and from 14:00 to 18:00

V2 reserves the right to make modifications to the product without any prior warning; furthermore, the company declines all responsibility for damages to people or property resulting from improper use or incorrect installation.

⚠ Read the following instruction manual thoroughly prior to proceeding with installation and programming of the system.

- This instruction manual is intended solely for use by technical staff, qualified in the field of installation of automation devices
- None of the information contained in the manual is of interest or use to end users.
- All maintenance or programming operations should be conducted exclusively by qualified staff.

The installation, testing and commissioning of door and gate automation devices should be performed by qualified and skilled personnel, who must assume responsibility for setting up the tests envisaged depending on the risks present; and verify compliance in accordance with legal and regulatory requirements.

- V2 accepts no responsibility for injuries and damage resulting from improper use of the product; other than that described in this manual.
- Packing materials must be disposed of in full compliance with local regulations.

DECLARATION OF CONFORMITY

The undersigned representing the following manufacturer:

V2 S.p.A.

Corso Principi di Piemonte 65, Racconigi (CN), ITALY

herein declares that the product **WES**

is in compliance with the provisions of the following community directives (including all applicable amendments)

99/5/CE

Directive regarding radio equipment and telecommunication terminal equipment and reciprocal recognition of their conformity

98/37/CE

concerning the harmonisation of legislation from member states regarding machinery

and that the technical standards indicated below have been applied:

EN 301 489-3: 2002

Electromagnetic compatibility and questions relating to the radiofrequency spectrum (ERM); electromagnetic compatibility (EMC) standards for radio equipment and services.

Part 3: specific conditions for short range devices (SRD) operating between the frequencies of 9 kHz and 40 GHz.

EN 300 328-1: 2001

Electromagnetic and radio spectrum compatibility (ERM); Broadband transmission systems. Data transmission equipment operating in the ISM band at 2.4 GHz using broad spectrum modulation techniques.

EN 12978 : 2003

Industrial, commercial and garage doors and gates - Safety devices for motorised doors and gates - Test methods and requirements

Racconigi, 12/10/2009

V2 S.p.A. Legal Representative

Cosimo De Falco

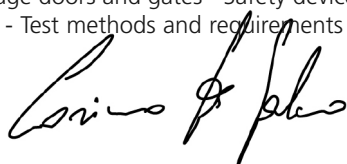

TECHNICAL INFORMATION

Base	
Power supply:	12 / 24 Vdc-ac
Input power:	0,75 W
Dimensions:	125x56x23 mm
Operating temperature:	-20/+60 °C
Outputs (relay switch):	2 edge alarms 1 low battery warning
Number of sensors:	until 8
Number of radio channels:	16

DESCRIPTION

WES (Wireless Edge System) is the new V2 system allowing safety edges to be controlled by radio.

The system consists of a base unit connected directly to the control unit, and one or more sensors (up to 8 per base unit) connected to the safety edges.

The base unit is powered from the control unit and constantly monitors the status of the sensors connected. Up to a maximum of 8 sensors may be connected to each base unit.

The system is compatible with standard safety edges with NC breakers, resistive safety edges (8k2).

The system is compatible with all control unit models.

System operation

The system operates independently of the status of the control unit. The relay corresponding to each sensor unit is kept closed if no edges are activated.

If an edge is pressed, the relay opens, signalling the anomaly to the control unit.

The base unit communicates with each sensor every 15 seconds, so as to verify their presence and function.

BASE UNIT INSTALLATION

⚠ PLEASE NOTE: The device should only be installed after having disconnected the power supply for the control unit to which the WES base unit is connected.

1. Install the base unit near the control unit; fix the casing using the specific fixing lugs **A**
2. Open the cover by unscrewing the 6 screws. Use one or two grommets **B** to allow the control unit connecting cable(s) to pass through
3. Connect the power supply to the **POWER** terminals. If using a DC supply, connect the positive pole to the **POWER+** terminal and the ground or common wire to the photocell transmitter power supply **POWER-** terminal
4. Connect the COM terminal to the control unit common (earth) inputs
5. Connect the (relay) outputs to the control unit inputs relating to the desired alarms:
 - Outputs **OUT1** and **OUT2** (breaker NC) open in the case of activation of one of the edges associated with UNIT 1 and UNIT 2* respectively.
 - The **BAT LOW** output (breaker NC) opens when a sensor indicates the low battery status

* **PLEASE NOTE:** UNIT 1 and UNIT 2 are used to manage 2 edge units in different modes. If the control unit has two separate inputs for safety edges, connect UNIT 1 (OUT1) to one input and UNIT 2 (OUT2) to the other, then program the control unit with the desired logics. If the control unit has only one input for edges, use output OUT 1 only.

6. Connect the START terminal to the photocell transmitter power supply terminal.
7. Power up the control unit and ensure that the green LED for the base unit is flashing normally after a few seconds. If the red LED remains on, this means the base has already been configured; it is necessary to delete the old configuration (see the section on **RESETTING THE BASE UNIT CONFIGURATION**)

PLEASE NOTE: when the device is powered up, up to 15 seconds may be required before the connection with all sensors is re-established. The system is ready for use when the LEDs for all the sensors are flashing at the scanning frequency set.

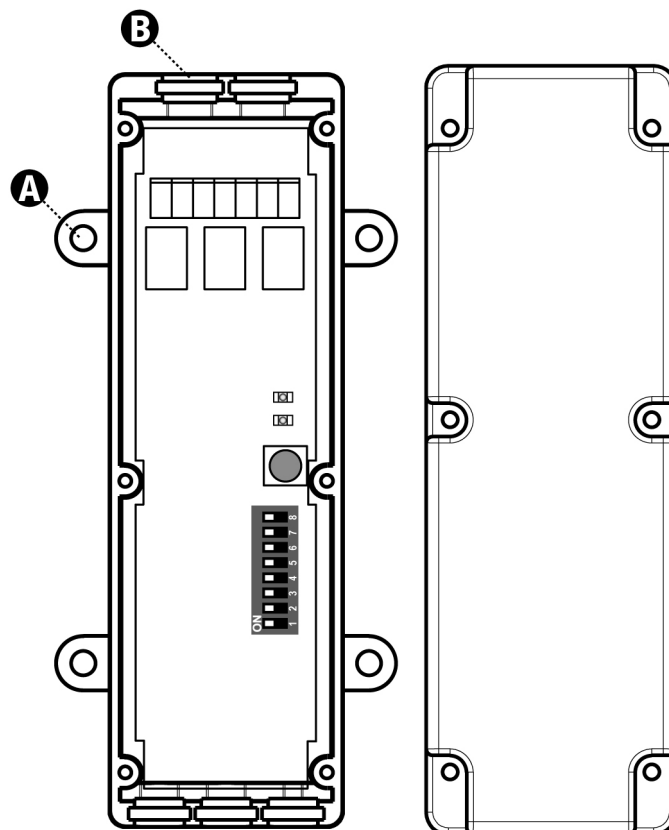

BASE UNIT ELECTRICAL CONNECTIONS

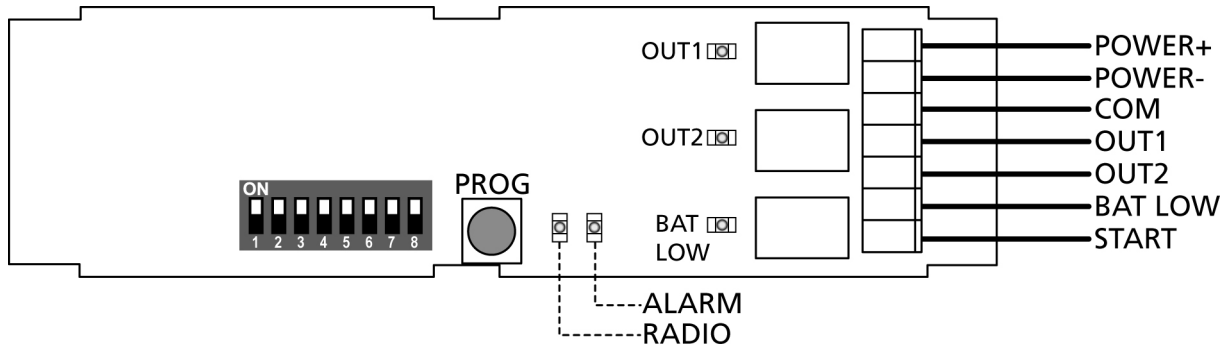

BASE UNIT	CONTROL UNIT
POWER+	System power - positive pole (12 / 24 Vdc-ac)
POWER-	System power – accessory supply COMMON
COM	Common safety input
OUT1	Unit 1 edge input
OUT2	Unit 2 edge input
BAT LOW	Can be used to indicate low battery level
START	Photocell TX supply

Mechanical or resistive edges

TERMINAL BOARD CONNECTIONS →		OUT1 COM	OUT2 COM	BAT LOW COM
A DEVICE WITH LOW BATTERY		-	-	A
BATTERIES OK	NO EDGE ACTIVATED	C	C	C
	EDGE 1 ACTIVATED	A	C	C
	EDGE 2 ACTIVATED	C	A	C

C – contact closed

A – contact open

DIP-SWITCHES

The device has 8 DIP-SWITCHES allowing the factory settings to be modified.

DIP-SWITCH	FUNCTION
1 - 2	RESERVED – leave as OFF
3 - 4 - 5 - 6	The various combinations of these DIP switches allows 1 of the 16 radio channels to be selected
7	RESERVED – leave as OFF
8	Activates the procedure for configuring the edge radio/Test channel

RADIO CHANNEL CONFIGURATION

When the network is not configured, the base unit monitors the 16 possible radio channels and registers activity present in the environment; for establishment of a new network, it is appropriate to select a channel on which there is low radio activity, in order to avoid interference.

Set dip-switch 8 to ON: the green and red LEDs indicate the quality of the channel selected:

- red LED: unusable channel
- green LED: single flash - medium quality
double flash – good quality
triple flash – best channel

Alter dip-switches 3 to 6 in order to change the radio channel until the best channel is identified.



PLEASE NOTE: Once the channel is selected, return dip-switch 8 to OFF



PLEASE NOTE: The channel cannot be modified after the network has been configured.

If dip-switches 3 to 6 are altered with the network configured, the red LED will emit a series of flashes in fours.

RESET BASE UNIT CONFIGURATION

To delete the configuration of a base, it is necessary to press and hold the PROG button on the base unit until the red LED starts to flash. Then release the button and repeat the radio channel configuration.

ASSOCIATING THE SENSOR WITH THE BASE

During association, the sensor communicates the installed configuration to the base.

NOTE: if a sensor is not connected to any edge, it cannot be associated with a base.

CAUTION: make sure edges are connected properly to the sensors prior to proceeding. When association is complete, it is no longer possible to alter the sensor connections.

Install the sensors by following the instructions attached to the product, then proceed as follows:

To associate an edge with **unit 1**, proceed as follows:

1. Press the PROG button on the base unit once: the ALARM LED emits single flashes
2. Press and hold the sensor SET button until LED L3 flashes intensely and regularly, then release the button.
3. The base automatically exits acquisition mode and the sensor starts to transmit with a period of 15 seconds

To associate an edge with **unit 2**, proceed as follows:

1. Press the PROG button on the base unit twice: the ALARM LED emits dual flashes
2. Press and hold the sensor SET button until LED L3 flashes intensely and regularly, then release the button.
3. The base automatically exits acquisition mode and the sensor starts to transmit with a period of 15 seconds

To associate an edge with **both units**, proceed as follows:

1. Press the PROG button on the base unit 3 times: the ALARM LED emits triple flashes
2. Press and hold the sensor SET button until LED L3 flashes intensely and regularly, then release the button.
3. The base automatically exits acquisition mode and the sensor starts to transmit with a period of 15 seconds

PLEASE NOTE: Association must be completed within 15 seconds, otherwise the base unit exits acquisition mode.

4. On completion, close the sensor casing and tighten the screws once more.
5. Repeat the operation for the other sensors in the network. When all the sensors have been installed and associated, close the base unit casing.

EDGE TESTING

Activate the base unit testing method by setting dip-switch 8 to ON. Press the edge to verify that:

1. the LED on the sensor remains fixed and on
2. the red (OUT1/OUT2) LED on the base unit comes on
3. The control unit recognises the alarm on the input where the output from the u



PLEASE NOTE: Remember to return dip-switch 8 to OFF on completion of the test.

LED SIGNALS ON THE BASE UNIT

CONDITION	GREEN LED (RADIO)	RED LED (ALARM)	LED OUT 1	LED OUT 2	LED BAT LOW
DIP-SWITCH 8 OFF					
NETWORK NOT CONFIGURED	• Flashes slowly	• Off	• Off	• Off	• Off
NETWORK CONFIGURED	• A brief flash with every message received (with just one sensor, the period is 15 sec.)	• Fixed on if there is no connection with a sensor • Series of 4 flashes if the network channel does not correspond with dip switch 3-6	• On when output OUT1 is activated (sensor alarm associated with unit 1)	• On when output OUT2 is activated (sensor alarm associated with unit 2)	• On when the LOW BAT output is activated (one of the sensors has a flat battery)
NETWORK CONFIGURATION ONGOING	• A brief flash with every message received • Slow flashing until at least one sensor is inserted in the network	• One, two or three flashes, depending on the unit being configured (button pressed once, twice or three times) • Slow flashing during network deletion (button pressed and held down)	• Off	• Off	• Off

CONDITION	GREEN LED (RADIO)	RED LED (ALARM)	LED OUT 1	LED OUT 2	LED BAT LOW
DIP-SWITCH 8 ON					
NETWORK NOT CONFIGURED	<ul style="list-style-type: none"> Channel quality <ol style="list-style-type: none"> Channels where maximum quality has been measured: green LED flashes 3 times Channels with near maximum quality: green LED flashes twice Channels with above-average quality: green LED flashes once Channels with below-average quality: red LED flashes once Channels with minimal quality: red LED flashes 3 times 		• Off	• Off	• Off
NETWORK CONFIGURED	• Fixed	• Fixed on if there is no connection with a sensor • Series of 4 flashes if the network channel does not correspond with dip switch 3-6	• On when output OUT1 is activated (sensor alarm associated with unit 1)	• On when output OUT2 is activated (sensor alarm associated with unit 2)	• On when the LOW BAT output is activated (one of the sensors has a flat battery)

FAULT FINDING PROCEDURE

Conduct fault-finding with the system off (door closed).

STEP	Action	Test	Diagnosis
1.	Open the base cover and observe the red LED	Is the LOW BAT LED on?	A sensor has a low battery; find the sensor with the flashing LED
2.		Is the ALARM LED on and fixed?	Communication problems between the sensors and the base. Find the sensor with the LED off or flashing very faintly
3.	Set dip switch 8 to ON: the ALARM LED initially comes on	Are the three OUT1, OUT2 and BAT LOW LEDs off?	The system is operating normally. If the control unit does not show that the edge input has been closed, there is a connection problem (broken wire)
4.	Observe the LED for a sensor	Is the LED on and fixed?	The sensor detects that the edge has been activated; connection problem or faulty edge
5.	Operate the edge	Does the LED on the sensor come on?	The sensor does not detect the status of the edge; connection problem or faulty edge
6.	-	Does the control unit indicate the edge input is closed?	Connection problems between the control unit and the base (short circuit)
7.	Repeat steps 4, 5 and 6 for each sensor	Are all sensors operating normally?	A non-existent sensor is included in the network. It is necessary to delete the network and repeat assignment of the sensors

 **PLEASE NOTE: Remember to set dip-switch 8 to OFF on completion of the procedure.**