

## IMPORTANT REMARKS

 **Prior to proceeding with installation, it is essential the instructions be read in full, since they contain important information regarding safety, installation, use and maintenance.**

### **AUTOMATION MUST BE IMPLEMENTED IN COMPLIANCE WITH THE EUROPEAN REGULATIONS IN FORCE:**

EN 60204-1, EN 12445, EN 12453, EN 13241-1, EN 12635

- The installer must provide for a device (es. magnetothermal switch) ensuring the omnipolar sectioning of the equipment from the power supply. The standards require a separation of the contacts of at least 3 mm in each pole (EN 60335-1).
- The plastic case has an IP44 insulation; to connect flexible or rigid pipes, use pipefittings having the same insulation level.
- Installation requires mechanical and electrical skills, therefore it shall be carried out by qualified personnel only, who can issue the Compliance Certificate concerning the whole installation (Machine Directive 2006/42/CEE, Annex IIA).
- Also the automation upstream electric system shall comply with the laws and rules in force and be carried out workmanlike.
- We recommend to make use of an emergency button, to be installed by the automation (connected to the control unit STOP input) so that the gate may be immediately stopped in case of danger.
- For correct installation of the system, we recommend following the instructions issued by UNAC very carefully.
- This instruction manual is only for qualified technicians, who specialize in installations and automations.
- The contents of this instruction manual do not concern the end user.
- Every programming and/or every maintenance service should be done only by qualified technicians.
- Anything not expressly described in these instructions is prohibited; unforeseen uses may be a source of danger to people and property.
- Do not install the product in explosive environments and atmospheres: the presence of inflammable gases or fumes is a serious safety hazard.
- Do not make any modifications to any part of the automation device, or the accessories connected to it, unless described in this manual.
- Any other modifications will void the warranty on the product.
- The installation steps should be conducted so as to avoid rainy weather, which can expose electronic circuits to dangerous water seepage.
- All operations requiring the casing of the device to be opened should be performed with the control unit disconnected from the electricity supply and with a warning notice displayed, for example: "CAUTION, MAINTENANCE IN PROGRESS".
- Avoid exposing the device close to sources of heat and flame.
- In the event of interventions on automatic or differential breakers or fuses, it is essential that faults be identified and resolved prior to resetting. In the case of faults that cannot be resolved using the information to be found in this manual, consult the V2 customer assistance service.
- V2 declines all responsibility for failure to comply with good construction practice standards in addition to structural deformation of the gate that might occur during use.
- V2 reserves the right to make modifications to the product without prior warning.
- Installation/maintenance personnel should wear individual protection devices (IPDs), such as overalls, safety helmets, boots and gloves.

- The ambient operating temperature should be that indicated in the technical characteristics table.
- The automation device should be shut down immediately in the event of any anomalous or hazardous situation; the fault or malfunction should be immediately reported to the person responsible.
- All safety and hazard warnings on the machinery and equipment should be complied with.
- Electromechanical actuators for gates are not intended to be used by people (including children) with diminished physical, sensory or mental capacity, or lacking in experience or knowledge, unless they are under supervision or have been instructed in use of the actuator by a person responsible for safety.

**V2 has the right to modify the product without previous notice; it also declines any responsibility to damage or injury to people or things caused by improper use or wrong installation.**



## DISPOSAL OF THE PRODUCT

As for the installation operations, even at the end of this product's life span, the dismantling operations must be carried out by qualified experts.

This product is made up of various types of materials: some can be recycled while others need to be disposed of. Find out about the recycling or disposal systems envisaged by your local regulations for this product category.

**Important!** – Parts of the product could contain pollutants or hazardous substances which, if released into the environment, could cause harmful effects to the environment itself as well as to human health.

As indicated by the symbol opposite, throwing away this product as domestic waste is strictly forbidden. So dispose of it as differentiated waste, in accordance with your local regulations, or return the product to the retailer when you purchase a new equivalent product.

**Important!** – the local applicable regulations may envisage heavy sanctions in the event of illegal disposal of this product.



## TECHNICAL SERVICE

For any installation problem please contact our Customer Service at the number +39-0172.812411 operating Monday to Friday from 8:30 to 12:30 and from 14:00 to 18:00.

## PRELIMINARY CHECKS AND IDENTIFICATION OF THE TYPE TO BE USED

It should be remembered that the device does not compensate for defects caused by improper installation, or poor maintenance, thus, prior to proceeding with installation, ensure that the structure is suitable and meets current standards and, if necessary, perform any structural modifications aimed at the implementation of safety gaps and the protection or segregation of all crushing, shearing and transit zones, and verify that:

- Your gate is equipped with a central latch.
- The gate has no friction points, either during closing or opening.
- The gate is well balanced, i.e. there is no tendency to move spontaneously when stopped in any position.
- The position identified for fixing the motor reducer allows easy and safe manual manoeuvring, compatible with the size of the motor reducer itself.
- The support on which the automation device will be fixed is solid and durable.
- The mains power supply to which the automation device is connected has a dedicated safety earthing system and differential breaker with tripping current less than or equal to 30 mA (the breaker gap distance should be greater than or equal to 3 mm).

**Warning: The minimum safety level depends on the type of use; please refer to the following outline:**

TYPE OF ACTIVATION COMMANDS	CLOSURE USE TYPE		
	GROUP 1 Informed people (use in private area)	GROUP 2 Informed people (use in public area)	GROUP 3 Informed people (unlimited use)
Man-present command	A	B	Not possible
Remote control and closure in view (e.g. infrared)	C or E	C or E	C and D or E
Remote control and closure not in view (e.g. radio)	C or E	C and D or E	C and D or E
Automatic control (e.g. timed closure control)	C and D or E	C and D or E	C and D or E

**GROUP 1** - Only a limited number of people are authorised for use, and closure is not in a public area. Examples of this type are gates inside business premises, where the sole users are employees, or a part of them who have been suitably informed.

**GROUP 2** - Only a limited number of people are authorised for use, but in this case, closure is in a public area. An example of this may be a company gate that accesses onto a public street, and which is only used by employees.

**GROUP 3** - Anyone can use the automated closure, which is thus located on public land. For example the access gate to a supermarket or an office, or a hospital.

**PROTECTION A** - Closure is activated by means of a control button with the person present, i.e. with maintained action.

**PROTECTION B** - With the person present, closure is activated by a command controlled by means of a key-switch or the like, in order to prevent use by unauthorised persons.

**PROTECTION C** - Restricts the force of the leaf of the door or gate. I.e., in the case of the gate striking an obstacle, the impact force must fall within a curve established by the regulations.

**PROTECTION D** - Devices, such as photocells, capable of detecting the presence of people or obstacles. They may be active on just one side or on both sides of the door or gate.

**PROTECTION E** - Sensitive devices, such as footboards or immaterial barriers, capable of detecting the presence of a person, and installed in such a way that the latter cannot be struck in any way by a moving leaf or panel. These devices should be active within the entire "danger zone" of the gate. The Machinery Directive defines "Danger Zone" as any zone surrounding and/or near machinery where the presence of an exposed person constitutes a risk to the health and safety of that person.

**The risk analysis should take into consideration all danger zones for the automation device, which should be appropriately protected and marked.**

**In a clearly visible area, apply a sign with information identifying the motorised door or gate.**

**The installer should provide the user with all the information relating to automatic operation, emergency opening and maintenance of the motorised door or gate.**

## USE LIMITATIONS

Before installing the product, check that the sizes and the weight of the gate leaf are within the limits stated in **CHART 1**.

kg - maximum gate leaf weight  
m - maximum gate leaf length

### WARNING

- Leaves exceeding 5 metres should not be panelled.
- Solenoid latch required for 4 m and above.
- Over 5 m, mechanical stops on the ground are required.

The correct gate opening movement, and the force that the motor must apply for such movement, depend on the position of the rear fastening bracket. Therefore, before proceeding with the installation, check **CHART 2** to calculate the maximum gate leaf opening angle and the motor force required for your system.

### CHART 1

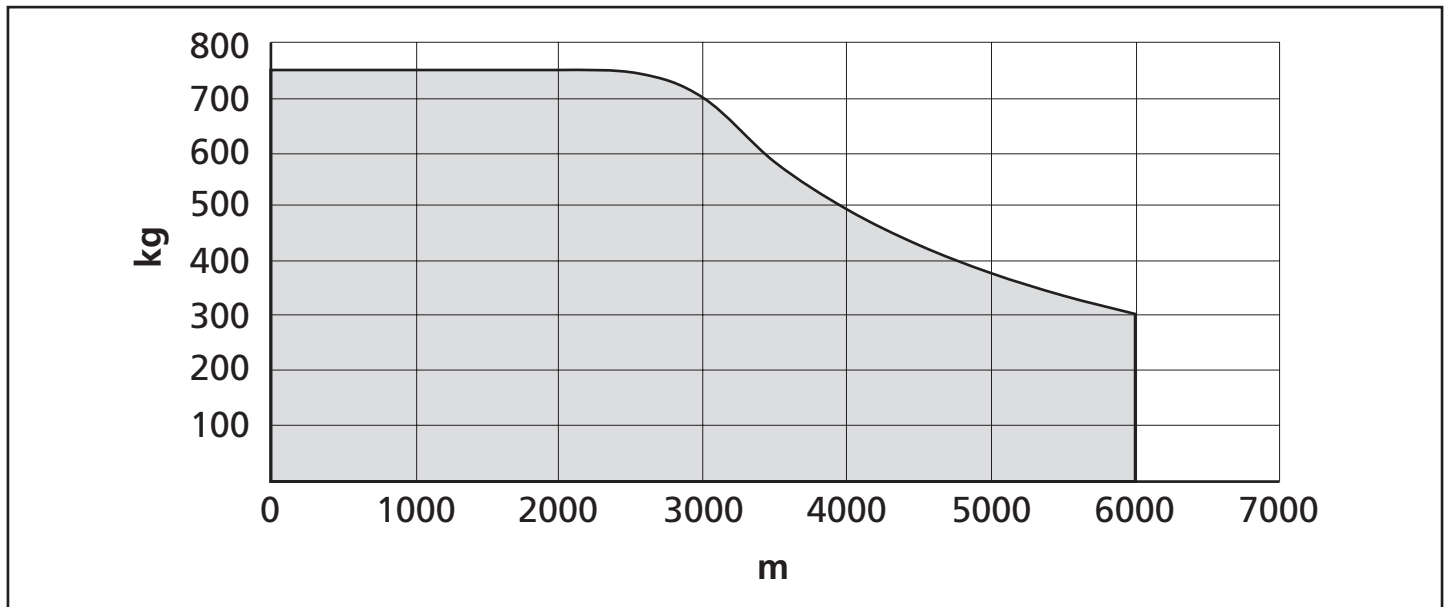

### CHART 2

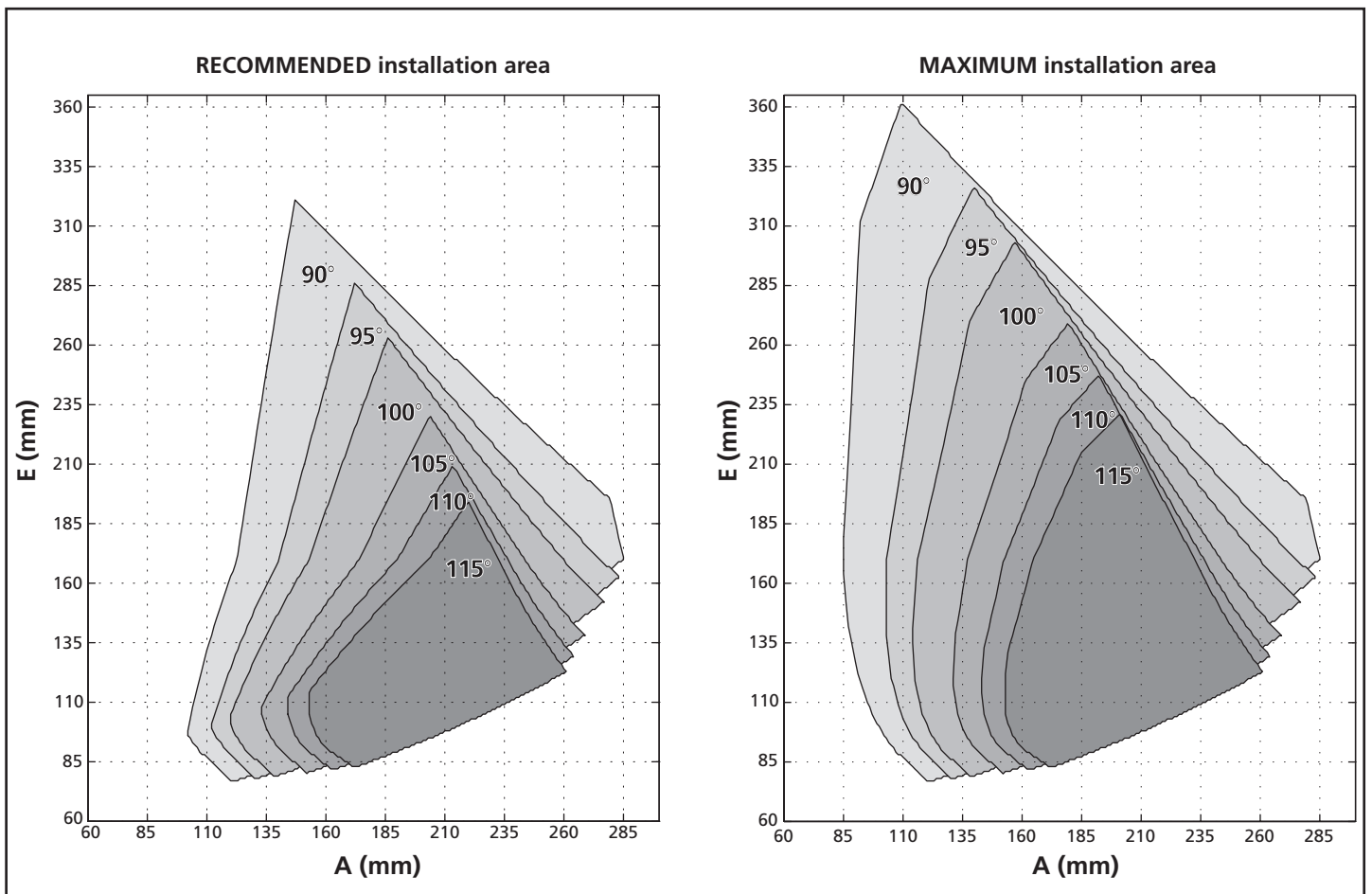

# INSTALLATION LAYOUT

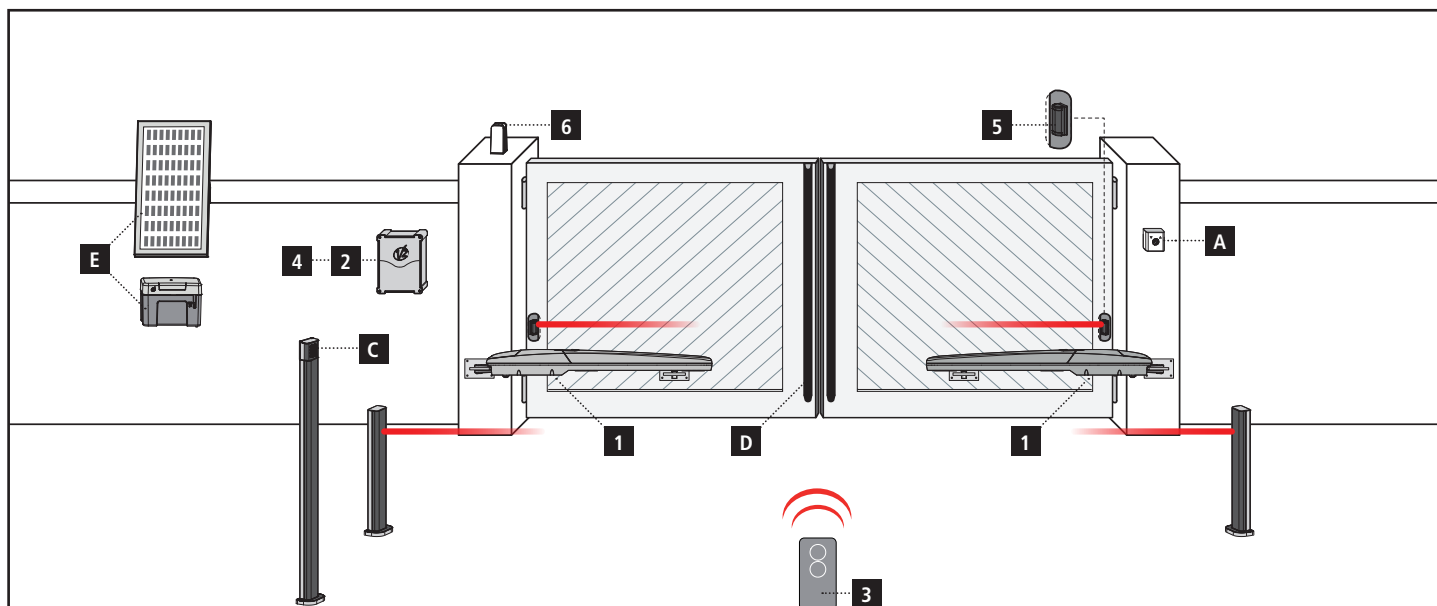

## COMPONENTS

- 1** Motor
- 2** Control unit
- 3** Transmitter
- 4** Receiving module
- 5** Photocells
- 6** Flashing light

## ADDITIONAL ACCESSORIES

- A** Key switch
- B** Pillar photocells
- C** Pillar-mounted digital radio switch
- D** Safety edges
- E** ECO-LOGIC system

LENGTH OF THE CABLE	< 10 metres	from 10 to 20 metres	from 20 to 30 metres
Power supply (230V)	3G x 1,5 mm <sup>2</sup>	3G x 1,5 mm <sup>2</sup>	3G x 2,5 mm <sup>2</sup>
24V motor power supply	2G x 1,5 mm <sup>2</sup>	2G x 1,5 mm <sup>2</sup>	2G x 2,5 mm <sup>2</sup>
Photocells (TX)	2 x 0,5 mm <sup>2</sup>	2 x 0,5 mm <sup>2</sup>	2 x 0,5 mm <sup>2</sup>
Photocells (RX)	4 x 0,5 mm <sup>2</sup>	4 x 0,5 mm <sup>2</sup>	4 x 0,5 mm <sup>2</sup>
Key switch	2 x 0,5 mm <sup>2</sup>	2 x 0,5 mm <sup>2</sup>	2 x 0,5 mm <sup>2</sup>
Safety edges	2 x 0,5 mm <sup>2</sup>	2 x 0,5 mm <sup>2</sup>	2 x 0,5 mm <sup>2</sup>
Flashing light	2 x 1,5 mm <sup>2</sup>	2 x 1,5 mm <sup>2</sup>	2 x 1,5 mm <sup>2</sup>
Antenna (integrated into the flashing light)	RG174	RG174	RG174
ECO-LOGIC (accumulator unit)	2 x 1,5 mm <sup>2</sup>	-	-
ECO-LOGIC (solar panel)	2 x 1 mm <sup>2</sup>	-	-

## DESCRIPTION OF THE PRODUCT

This product has been designed to automate gates or doors with leaf opening, for residential or industrial use.

### **⚠ CAUTION!**

Any other use different to that described and in ambient conditions different to those set out in this manual is to be considered improper and forbidden!

The product is an electromechanical gear motor, equipped with a 24V continuous current alternate current motor and an endless screw reduction gear.

The gear motor is powered by the external control unit to which it is connected.

In the event of a black out, it is possible to move the gate leaves by hand, unblocking the gear motor manually.

Fig. 1 shows all the components provided in the package:

- a** - electromechanical gear motor
- b** - front bracket and plate (for fixing the gear motor to the gate leaf)
- c** - rear bracket and plate (for fixing the gear motor to the wall)
- d** - metal parts (screws, washers, etc.)
- e** - keys to manually unlock the gear motor

## TECHNICAL DATA

Max. leaf length	m	6
Max. leaf weight	Kg	750
Power supply	Vdc	24
Idling current	A	0,8
Full load current	A	7
Electric power	W	170W
Opening time of the leaf 0÷90°	s	28
Max travel	mm	540
Operating speed (unloaded)	m/s	0,016
Operating speed (full load)	m/s	0,012
Maximum thrust	N	2400
Working temperature	°C	-20 ÷ +55
Protection	IP	44
Working cycle	%	80
Motor weight	Kg	9

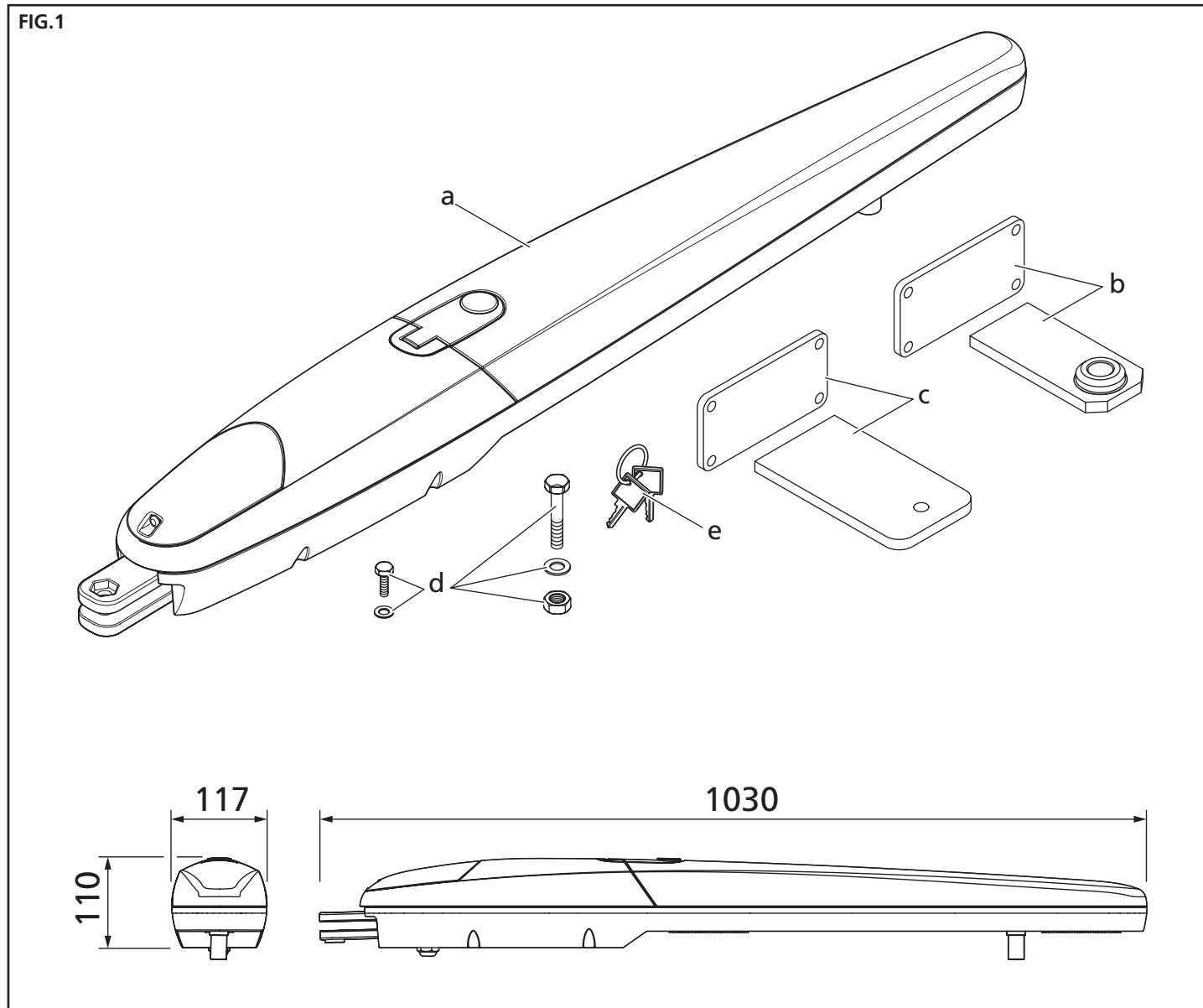

## INSTALLATION OF THE REAR FIXING BRACKET

Calculate the rear bracket position using **CHART 2**.

This chart is used to define distances **A** and **E** and the maximum opening angle of the gate leaf.

**Important - Distances A and E must be similar, to ensure a linear automation movement.**

We suggest that the values inside the recommended installation area are used; only consider the maximum installation area if staying within the recommended values is not possible.

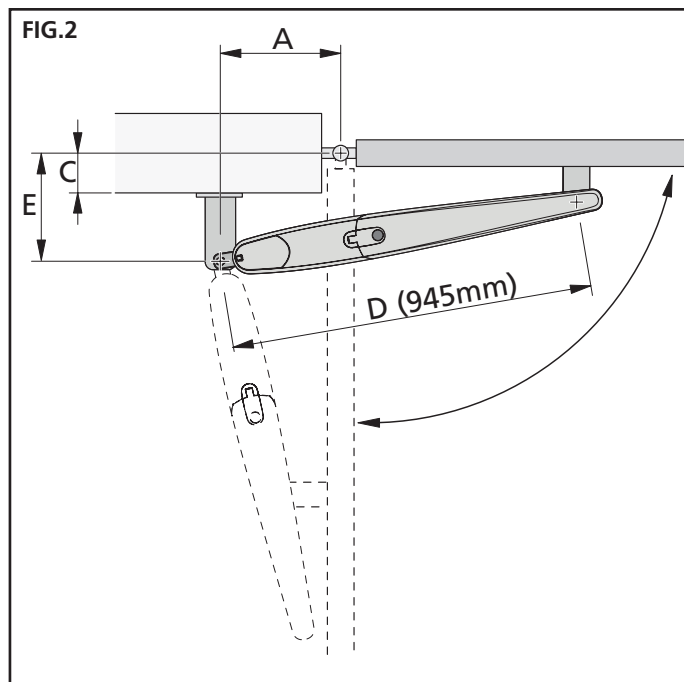

1. Measure value **E**, and then trace a straight horizontal line by that value.
2. Select a point in the line, taking into account the desired opening angle, suitable for the column. Trace a straight vertical line starting from the identified point, and obtain value **A**.
3. Before proceeding with the installation, make sure that value **A** allows to fix the rear bracket, otherwise select another point on the chart.
4. Lastly, to fix the bracket move the piston to the limit of the stroke (see Fig. 2).

**CAUTION: Failure to comply with the bracket installation distances may lead to automation operation faults, such as:**

- Cyclical movements and accelerations at some positions of the stroke.
- Increased motor noise.
- Limited opening, or no opening at all (in case of counter-lever fixed motor).

5. Before it can be fixed to the wall, the bracket must be welded to the fastening plate (Fig. 3); the bracket may be cut to the desired length, adjusting distances **A** and **E** accordingly

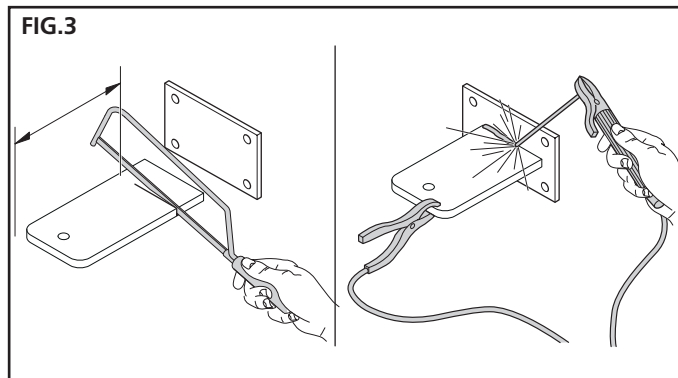

**NOTE - The bracket supplied with the gearmotor is 180 mm long**

**⚠ WARNING! – Before fixing the rear bracket, make sure that the front bracket will be fixed to a solid position of the gate leaf; the front bracket will have to be secured at a different height than the rear bracket (Fig. 4).**

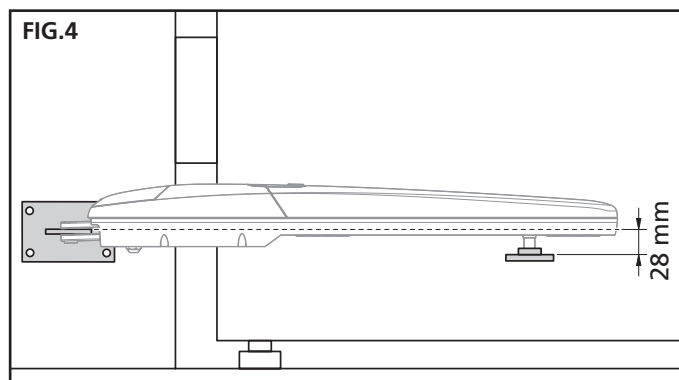

6. Fix the bracket in place using suitable plugs, screws and washers (not supplied)

## INSTALLATION OF THE FRONT FIXING BRACKET

1. For the installation of the front bracket to the gate leaf, refer to distance **D** (fig. 2).
2. Define the front bracket installation height in accordance with fig. 4.
3. Fix the bracket to the solid section of the gate leaf.

## SECURING THE GEARMOTOR TO THE FIXING BRACKETS

1. Secure the gearmotor to the rear bracket:

**NOTE:** if the rear bracket is not completely level, the back tilting section can help compensate for any axis misalignments between the two brackets (+/-5°).

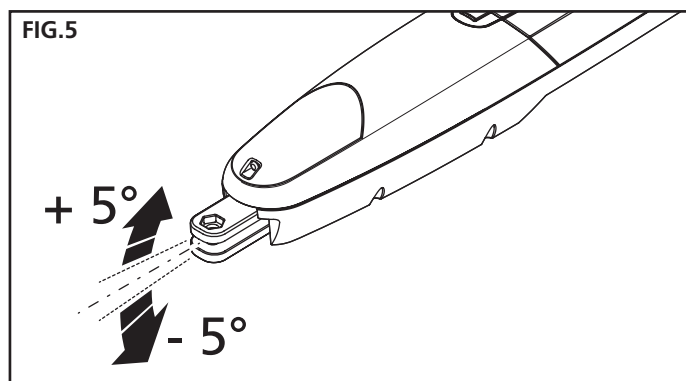

2. Secure the gearmotor to the bracket as shown in fig. 6, using the screw, washer and nut supplied;
3. Fully tighten the nut and then loosen it again by approximately 1/10 of a turn, to allow a minimum clearance between the parts.

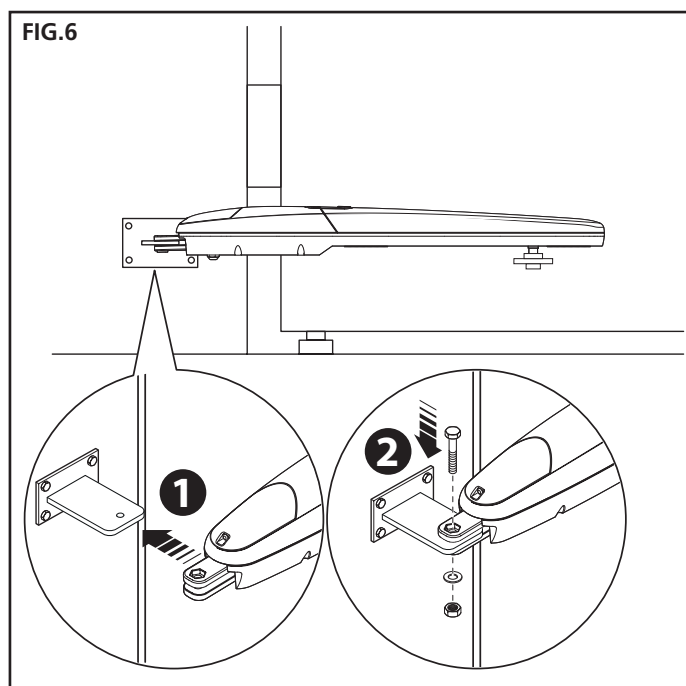

4. Secure the gearmotor to the front bracket.
5. Secure the gearmotor to the bracket as shown in fig. 7, using the screw and the washer supplied.
6. Fully tighten the screw.

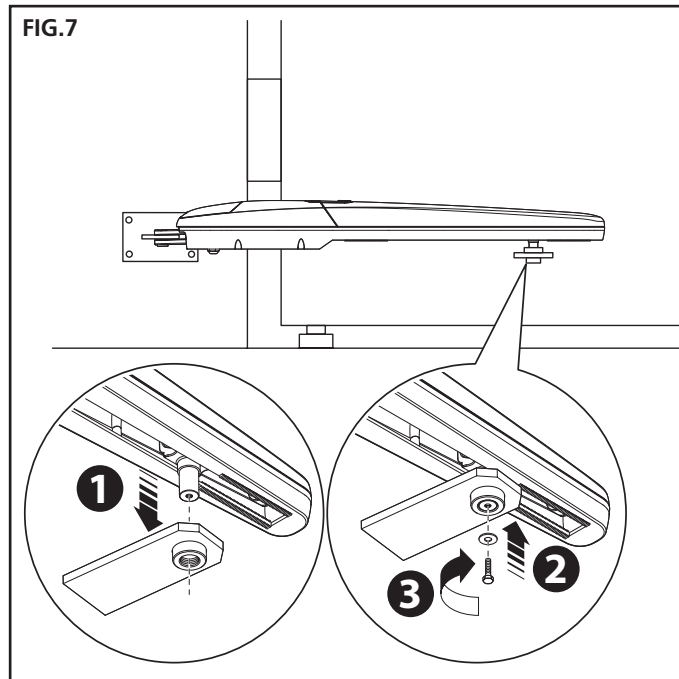

## ADJUST THE END OF STROKES

1. Release the gearmotor as shown in fig. 8.

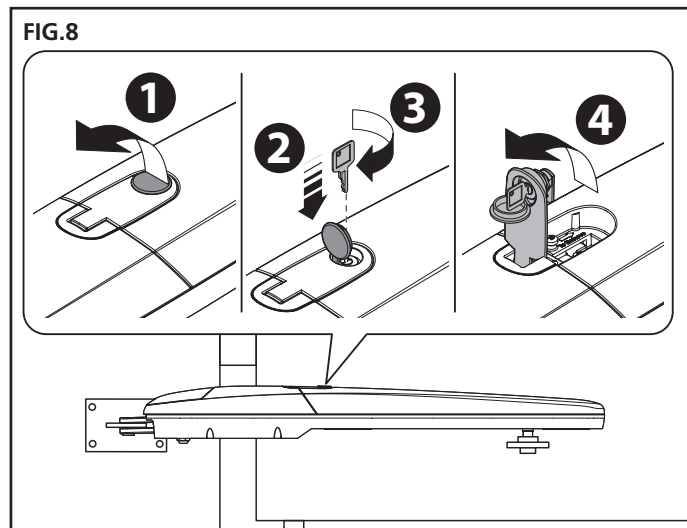

2. Remove the 2 screws underneath the handle and remove the cover as shown in fig. 9.

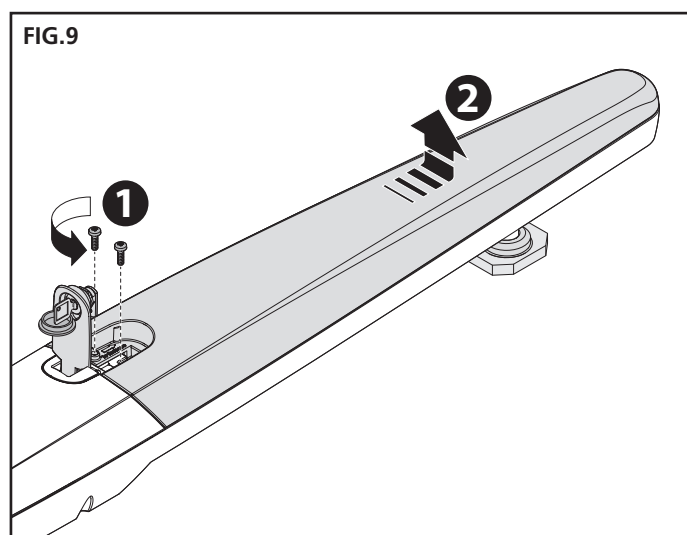

3. Manually move the gate leaf until the mechanical stop screw is visible; loosen the screw (fig. 10)

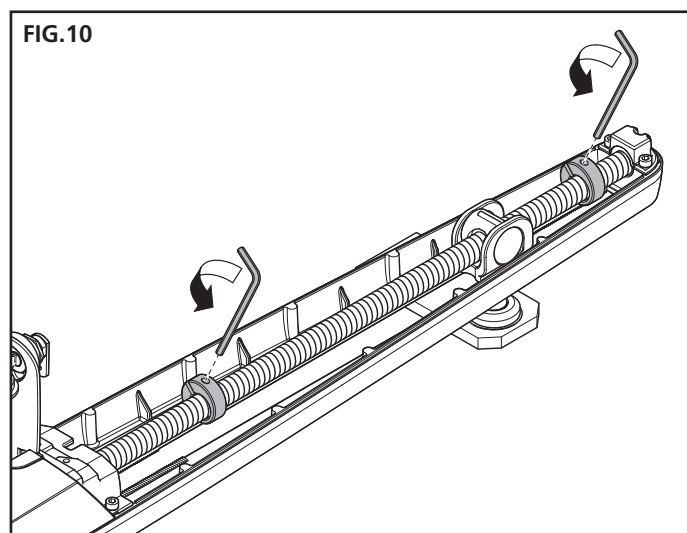

4. Manually move the gate leaf to the desired open position.
5. Move the mechanical stop against the pin and tighten the screw (fig. 11).

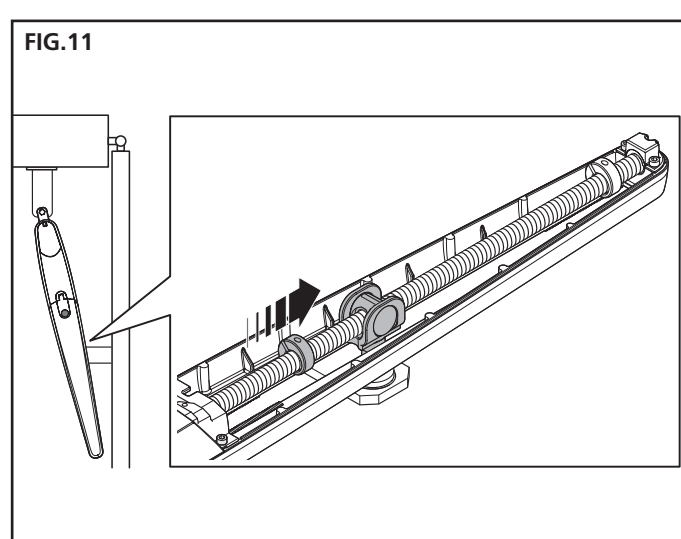

6. Now repeat the procedure by manually moving the gate leaf to the maximum closed position, to adjust the closing limit switch (fig. 12).

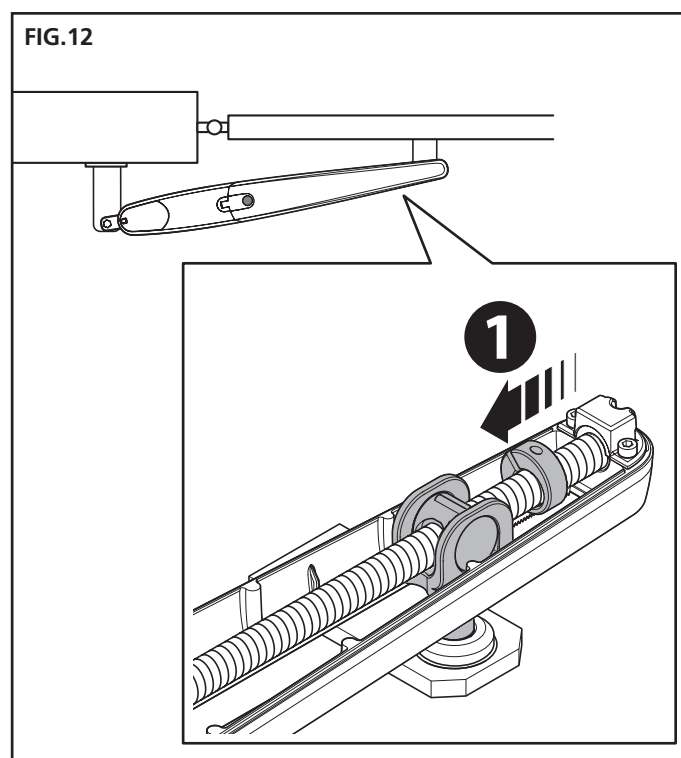

7. Replace the cover and tighten the two screws.
8. Lock the gearmotor..

## ELECTRICAL CONNECTIONS

### CAUTION!

- A wrong connection can cause faults or danger; therefore follow scrupulously the connections set out.
- Perform the connection operations when the electricity is off.

To connect the gear motor to the control unit, proceed as follows:

1. Remove the lid of the gear motor as shown in fig. 13.

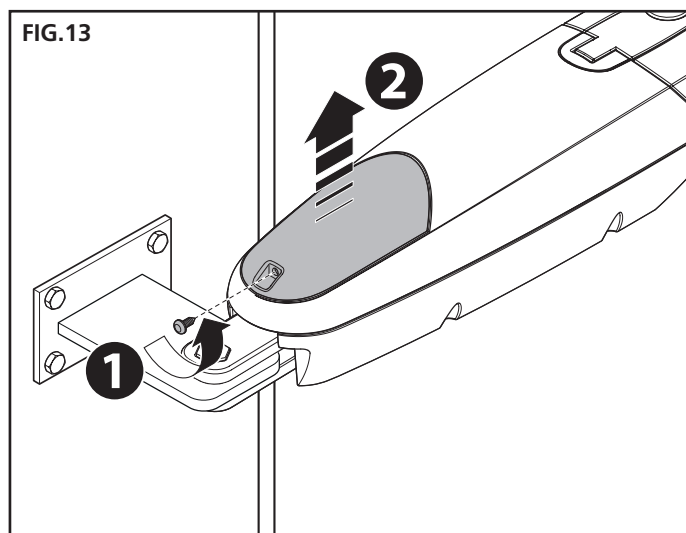

2. Loosen the cableway of the gear motor and insert the connecting cables inside it (fig. 14)

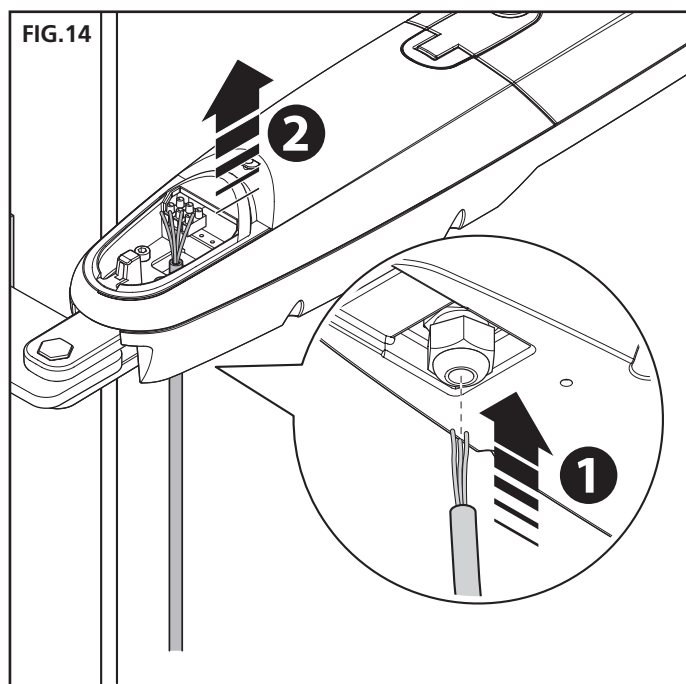

3. Connect the various wires and grounding cable, exactly as shown in the wiring diagram of fig. 15

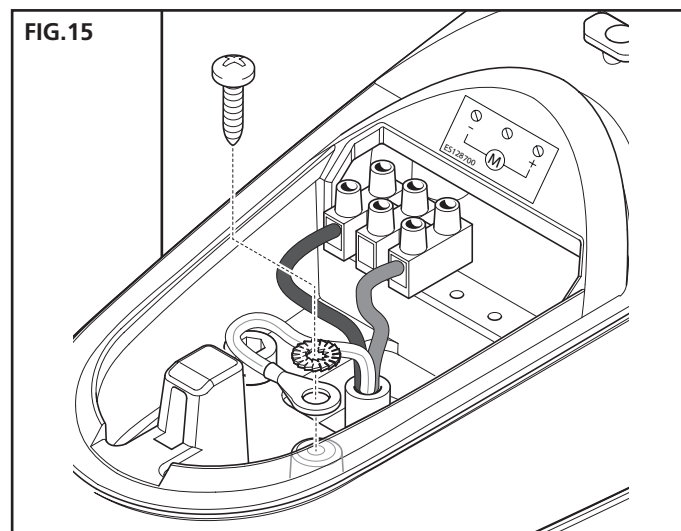

4. Replace lid on gear motor.

**To check the connections, direction of rotation of the motor, phase shift in the movement of the leaves and setting the limit switch, refer to the instructions manual of the control unit.**

# EU DECLARATION OF CONFORMITY AND DECLARATION OF INCORPORATION OF PARTLY COMPLETED MACHINE

Declaration in accordance with Directives: 2014/35/UE (LVD);  
2014/30/UE (EMC); 2006/42/CE (MD) ANNEX II, PART B

The manufacturer (\*) V2 S.p.A., headquarters in Corso Principi di  
Piemonte 65, 12035, Racconigi (CN), Italy

Under its sole responsibility hereby declares that:  
the partly completed machinery model(s):  
STARK6-24V

Description: electromechanical actuator for gates

- is intended to be installed on gates, to create a machine according to the provisions of the Directive 2006/42/EC. The machinery must not be put into service until the final machinery into which it has to be incorporated has been declared in conformity with the provisions of the Directive 2006/42/EC and 89/106/CE.
- is compliant with the applicable essential safety requirements of the following Directives:  
Machinery Directive 2006/42/EC (annex I, chapter 1)  
Low Voltage Directive 2014/35/EU  
Electromagnetic Compatibility Directive 2014/30/EU  
Directive ROHS2 2011/65/CE

The relevant technical documentation is available at the national authorities' request after justifiable request to:  
V2 S.p.A., Corso Principi di Piemonte 65, 12035, Racconigi (CN),  
Italia

The person empowered to draw up the declaration and to provide the technical documentation:

**Sergio Biancheri**

Legal representative of V2 S.p.A.  
Racconigi 18/12/2018

